

### Project 16.1: Atomic Force Microscopy (1)

In this project you will learn about torque and angular momentum, and we will use this to study a simple model of an Atomic Force Microscope (AFM).

An Atomic Force Microscope (AFM) is a device used to measure forces on an atomic scale. A sketch showing the principle of an AFM is shown in figure 16.36. The AFM consists of a cantilever – a beam attached at one end. In the other end is a small triangle – the probe. If a force acts on the probe, as indicated in figure 16.36, the beam bends an angle  $\theta$ . For small deflections, the angle is proportional to the force applied. We can measure the angle precisely by shining a laser beam on the beam and measuring the deflection of the laser beam. This technique is routinely used today, and you can buy commercial devices that can be used to measure details down to the atomic level and forces down to picoNewtons.

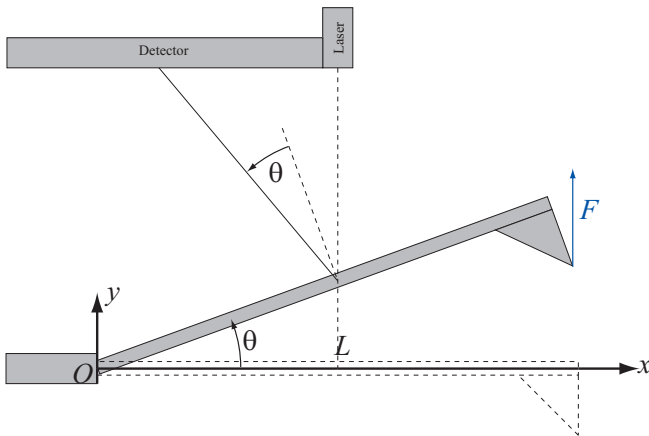

**Figure 16.36:** Illustration of an Atomic Force Microscope. Due to an applied force  $F$ , the beam bends an angle  $\theta$ . In the real system, the whole beam bends, but in this sketch, we have assumed that the beam bends only in the point  $O$ .

In this project we are going to develop a simple model for the AFM, and study the behavior of the model AFM as it is moved through a fluid and picks up a large molecule. We will do this in several steps. First, we will study the collision between a macroscopic beam and a particle. Then we will introduce a model for the torque on a bending beam. We apply this model to study a collision between the beam and a macromolecule.

First, we will familiarize us with a collision between a homogeneous beam of length,  $L$ , mass  $M$  attached with a frictionless hinge in point  $O$  at one of the endpoints of the beam. The moment of inertia of the beam for rotations around the point  $O$  in the direction given by the hinge is  $I$ . The beam is macroscopic and affected by gravity. The acceleration of gravity is  $g$  in the negative  $y$ -direction. Initially, the beam hangs straight down in the negative  $y$ -direction, as illustrated in figure 16.37. A small bullet of mass  $m$  is fired along the  $x$ -axis, hitting the beam at the bottom. The bullet has an initial velocity  $v_0$  and remains lodged in the beam after the collision.

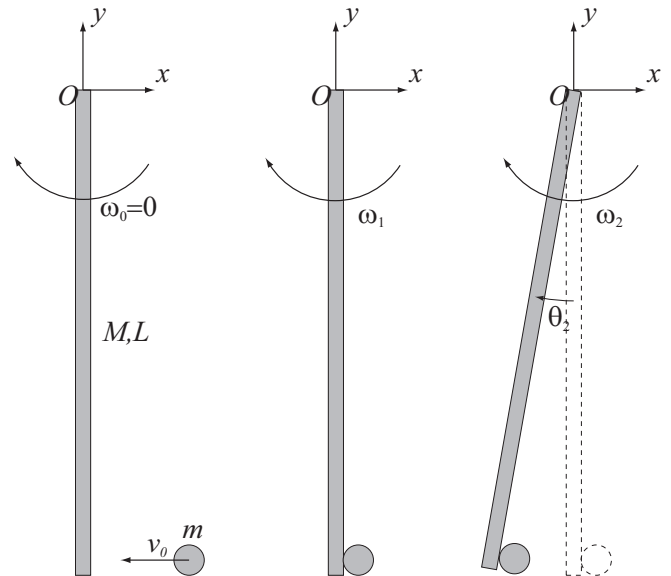

**Figure 16.37:** Illustration of a collision between a beam and a small bullet. Initially (situation 0), the beam hangs down without moving, and the bullet moves with a velocity  $v_0$ . After the collision (situation 1), the beam and the bullet moves with an angular velocity  $\omega_1$ . When the beam has reached an angle  $\theta_2$  (situation 2), the angular velocity of the beam is  $\omega_2$ .

- What is the angular momentum,  $L_0$ , around the point  $O$  of the system consisting of the beam and the bullet before the collision?
- What is the angular momentum,  $L_1$ , around the point  $O$  after the collision?
- What is the total moment of inertia,  $I_T$ , of the beam and the bullet around  $O$ ?
- What is the angular velocity,  $\omega_1$ , of the beam (with the bullet attached) after the collision?
- (Difficult) Show that the linear momentum of the system is generally not conserved during the collision. In what special case would the linear momentum of the system be conserved?
- Find the angular acceleration  $\alpha_2$  of the beam (with the bullet) as a function of the angle  $\theta_2$  for situation 2 figure 16.37.
- Find the maximum value of  $\theta$  that the beam reaches after the collision.

We will now start addressing the AFM system. In the AFM system, the beam is not free to rotate around the point  $O$ , but there are beam bending forces that resist the bending motion. In this case, the effects of gravity will be negligible compared to the torque on the beam due to bending. When the beam bends

an angle  $\theta$ , as illustrated in figure 16.36, there will be a bending moment  $\tau_b$  acting on the beam in the point  $O$ . First, let us estimate the torque due to the beam bending.

(h) (Optional) We will make a simple model for the bending of the beam in the point  $O$ . We assume that the beam is bent as illustrated in figure 16.38. The top part of the beam is compressed and the bottom part of the beam is extended. We assume that we can model the forces due to the compression and the extension by a simple spring force, with a spring constant  $k$ . First, show that that the extension at the bottom of the beam is

$$\Delta x \simeq \left(\frac{h}{2}\right)\theta. \tag{16.193}$$

The compression at the top of the beam has a similar form. Now, show that the torque on the beam around the center of the beam is:

$$\tau_b \simeq 2(h/2)(-k(h/2)\theta) = -k\left(\frac{h^2}{2}\right)\theta \tag{16.194}$$

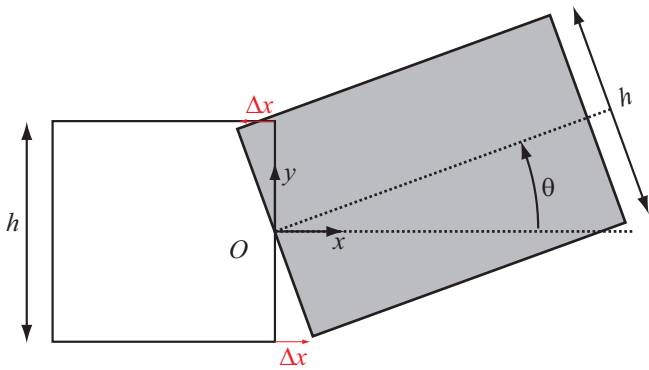
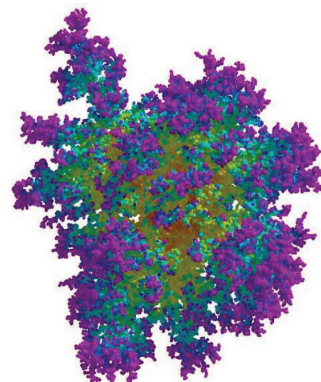

**Figure 16.38:** Illustration of force acting on the beam at the point  $O$  due to an extension (at the bottom) and a compression (at the top).

### Project 16.2: Snow crystal

In this project you will apply your knowledge of linear and angular momentum to study the aggregation of small droplets of ice to form large grains of snow.

As snow crystals form in clouds they start falling through the cloud. Due to air resistance, larger particles fall faster than smaller particles. A large particle will therefore overtake smaller particles. When a smaller particle is overtaken, it will stick to the larger particle, adding further to the size. This process forms aggregate snowflakes, which is one of the most common types of snowflakes.<sup>4</sup> This mechanism is often called differential sedimentation, and is a process important for pattern formation in many natural systems, and it is also a process important for many industrial processes. An example of a complex aggregate formed by a related aggregation process called Diffusion Limited Aggregation in figure 16.39 shows the complex geometries typically found in aggregate grains.



**Figure 16.39:** Image of a (fractal) cluster formed by diffusion limited aggregation of 10000 particles. (Goold, 2004).

In the following we will assume that the bending torque,  $\tau_b$ , on the beam is

$$\tau_b = -\kappa\theta. \tag{16.195}$$

- (i) We move the AFM vertically (in the  $y$ -direction). The AFM beam is affected by a force  $F$  that acts at the tip of the triangle. The force is directed in the positive  $y$ -direction. Find the net torque around  $O$ ,  $\tau_O$ .
- (j) We use the AFM to measure the force  $F$ . How can we find the force  $F$  from the angle  $\theta$  of the beam? (You need to find  $\theta$  as a function of  $F$ .)

In the following, you can use that the potential energy of the beam due to the bending torque is

$$U_b = \frac{1}{2}\kappa\theta^2. \tag{16.196}$$

- (k) (Optional) Prove that equation 16.196 is the potential energy of the system.
- (l) (Difficult) We move the AFM at a constant speed  $v$  downwards (in the negative  $y$ -direction). A large molecule with mass  $m$  attaches to the tip of the AFM. How can we use the maximum angle  $\theta$  of the oscillations of the AFM to determine the mass  $m$ ? You can assume that the AFM beam is very long compared to the size of the triangular tip.

<sup>4</sup>You can learn more about this process, and look at how aggregate flakes look in the PhD thesis of Christopher David Westbrook at <http://www.met.rdg.ac.uk/sws04cdw/thesis.pdf>