

UiO : Department of Informatics
University of Oslo

IN5230

Electronic noise – estimates and countermeasures

Lecture no 7 (Mot3)

Noise in amplifiers with feedback



UiO : Department of Informatics
University of Oslo

So far we have discussed the amplifiers without feedback ("open loop"). Now we will discuss the impact of feedback.

In general feedback is used to...

- change the gain,
- change impedances,
- change the frequency response,
- reduce distortions etc.

NB! Feedback loops does not reduce the input noise! (Resistance in the feedback will add more noise.) However it may/should reduce instability!

This will be shown in the following

Cascoded amplifiers with feedback

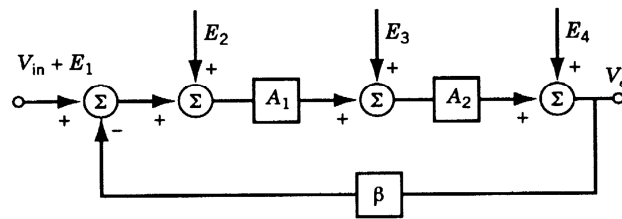

Figure 3-1 Two-stage amplifier with feedback for determining the effects of noise.

V_{in} : The input signal

E_1, E_2, E_3, E_4 : Noise

A_1, A_2 : Voltage gain in the two amplifiers

β : Voltage gain in the feedback network

V_o : Total signal on output. V_o can be expressed as:

$$V_o = E_4 + A_2 [E_3 + A_1 (E_2 + V_{in} + E_1 - \beta V_o)]$$

We rearrange so that V_o is on the left:

$$V_o = \frac{A_1 A_2}{1 + A_1 A_2 \beta} (V_{in} + E_1 + E_2) + \frac{A_2 E_3}{1 + A_1 A_2 \beta} + \frac{E_4}{1 + A_1 A_2 \beta}$$

IN5230

Noise in amplifiers with feedback

3

Cascoded amplifiers without feedback

In this case we entitle the gain in stage 2 as A'_2 . All others are identical with the values of the amplifier chain with feedback.

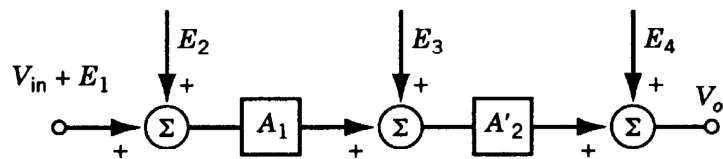

Figure 3-2 Open-loop amplifier used for comparison.

$$V_o = A_1 A'_2 (V_{in} + E_1 + E_2) + A'_2 E_3 + E_4$$

In order to compare with and without feedback, we chose A'_2 so that the amplification of V_{in} to the output is equal for both cases:

$$A'_2 = A_2 / (1 + A_1 A_2 \beta)$$

With this value for A'_2 we will end up with:

$$V_o = \frac{A_1 A_2}{1 + A_1 A_2 \beta} (V_{in} + E_1 + E_2) + \frac{A_2 E_3}{1 + A_1 A_2 \beta} + E_4$$

IN5230

Noise in amplifiers with feedback

4

Comparing with and without feedback

We compare the expression for the amplifier chain with feedback:

$$V_o = \frac{A_1 A_2}{1 + A_1 A_2 \beta} (V_{in} + E_1 + E_2) + \frac{A_2 E_3}{1 + A_1 A_2 \beta} + \frac{E_4}{1 + A_1 A_2 \beta}$$

with the expression for the amplifier chain without feedback:

$$V_o = \frac{A_1 A_2}{1 + A_1 A_2 \beta} (V_{in} + E_1 + E_2) + \frac{A_2 E_3}{1 + A_1 A_2 \beta} + E_4$$

We see that with or without feedback makes no difference for the noise on the inputs (E_1 , E_2 and E_3).

Noise at the output (E_4) will be muted through the feedback. E_4 may come from, say, a noisy load.

Noise model for differential amplifier

Most amplifiers are built around a differential amplifier core. Besides being used for two differential signals they can be used for signals in a single inverting or single non-inverting topology decided by a network of external components. A noise model must cover all of these topologies

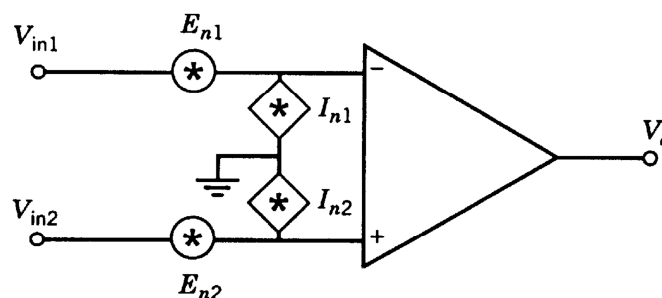
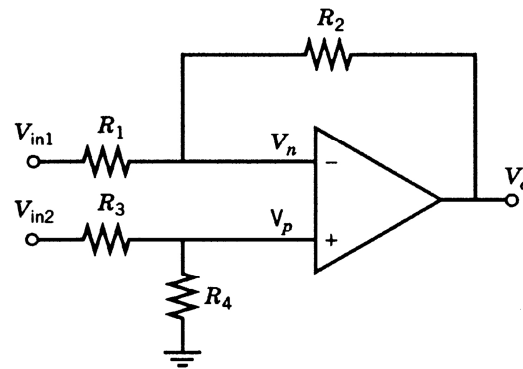

Figure 3-3 Amplifier noise and signal source.

Red:
Figure

Differential amplifier setup



(a)

Red:
Figure

The figure shows an ordinary differential network around an amplifier. The output voltage can be expressed as:

$$V_o = \left(\frac{R_4}{R_3 + R_4} \right) \left(\frac{R_1 + R_2}{R_1} \right) V_{in2} - \left(\frac{R_2}{R_1} \right) V_{in1}$$

IN5230

Noise in amplifiers with feedback

7

We have an ideal differential amplifier when the signal on the positive and negative input have the same but opposite gain.

This is the case when:

$$R_2 / R_1 = R_4 / R_3$$

In this case, we have:

$$V_o = \left(R_2 / R_1 \right) \left(V_{in2} - V_{in1} \right)$$

IN5230

Noise in amplifiers with feedback

8

Variations

- 1: Differential (as already discussed)
 - 2: Non-inverting ($V_{in1}=0$)
 - 3: Inverting ($V_{in2}=0$)
 - 4: Addition and subtraction of multiple values implemented with resistors
 - 5: Addition and subtraction of multiple values implemented with switch-mode capacitors
- ⇒(Resistors ⇒ thermal noise
Capacitors ⇒ switch noise)

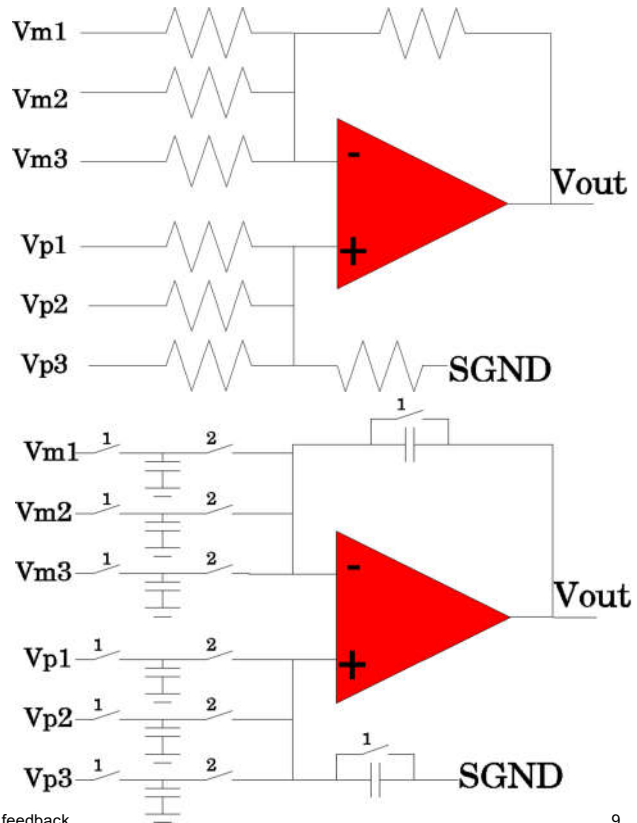

IN5230

Noise in amplifiers with feedback

9

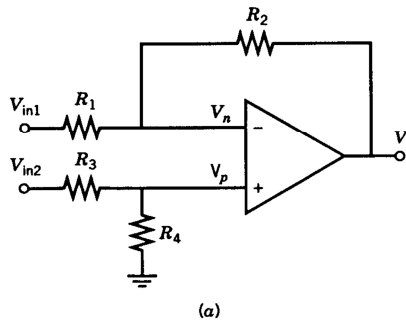

(a)

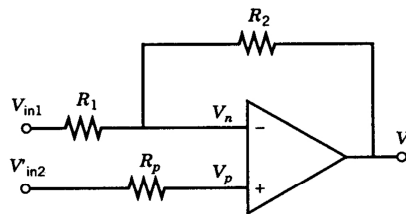

(b)

Thevenin equivalent circuit:

In b), we have made an equivalent circuit of a) where:

$$R_p = R_3 \parallel R_4 \quad \text{and} \quad V'_{in2} = (R_4 V_{in2}) / (R_3 + R_4)$$

Figure 3-4 Differential amplifier using one op amp: (a) complete circuit and (b) reduced circuit.

IN5230

Noise in amplifiers with feedback

10

We extend the schematic by adding models for noise sources:

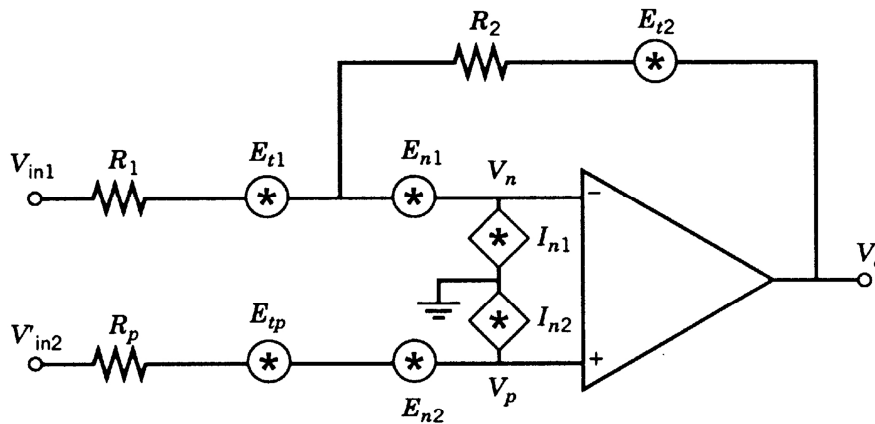

Figure 3-5 Differential amplifier with all noise sources in place.

E_{n1} , E_{n2} , I_{n1} and I_{n2} are noise models for the amplifier. The other noise sources are noise models for the resistors.

IN5230

Noise in amplifiers with feedback

11

Yellow:
Figure

It will be somewhat complicated to calculate the rms values. Instead we choose to replace the noise sources with small voltage and current sources. We also choose to set a polarity of the sources as specified in the figure.

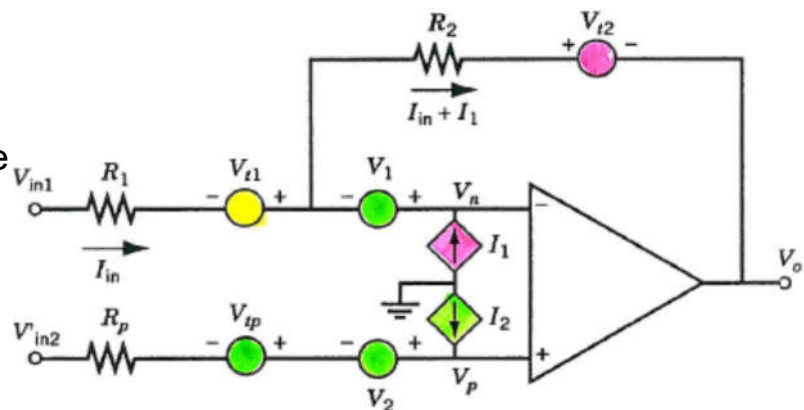

Figure 3-6 Differential amplifier with signal sources in place.

We let A be the voltage gain when the amplifier has no feedback (i.e. "open loop").

We have then:

$$V_o = A(V_p - V_n)$$

$$V_p = V'_{in2} + R_p I_2 + V_{tp} + V_2$$

$$V_n = V_{in1} - R_1 I_{in} + V_{t1} + V_1$$

$$V_{in1} - R_1 I_{in} + V_{t1} = V_o + V_{t2} + R_2 (I_{in} + I_1)$$

IN5230

Noise in amplifiers with feedback

12

We put together the expressions on the previous page so that we get rid of V_p , V_n and I_n .

$$V_o \left(\frac{1}{A} + \frac{R_1}{R_1 + R_2} \right) = V'_{in2} - V_{in1} + V_2 - V_1 + V_p - V_{t1} + R_p I_2 + \left(\frac{R_1}{R_1 + R_2} \right) (V_{in1} + V_{t1} - V_{t2} - I_1 R_2)$$

We let the operation amplifier be ideal by letting A go to infinity and then we will have:

$$V_o = \left(1 + \frac{R_2}{R_1} \right) (V'_{in2} + V_2 + V_p + I_2 R_p - V_1) - \frac{R_2}{R_1} (V_{in1} + V_{t1}) - V_{t2} - I_1 R_2$$

The expressions in front of each voltage or current will indicate the gain.

We will now switch back to the noise considerations by replacing the voltages that represents noise (V) with noise (E^2). Since we calculate RMS we must square all terms. Since we will only look at the noise, we must also remove the voltages that represents the signal voltages, i.e. V_{in1} and V'_{in2} . We will then have:

$$E_{no}^2 = \left(1 + \frac{R_2}{R_1} \right)^2 (E_{n2}^2 + E_{tp}^2 + I_{n2}^2 R_p^2 + E_{n1}^2) + \left(\frac{R_2}{R_1} \right)^2 (E_{t1}^2) + E_{t2}^2 + I_{n1}^2 R_2^2$$

IN5230

Noise in amplifiers with feedback

13

$$E_{no}^2 = \left(1 + \frac{R_2}{R_1} \right)^2 (E_{n2}^2 + E_{tp}^2 + I_{n2}^2 R_p^2 + E_{n1}^2) + \left(\frac{R_2}{R_1} \right)^2 (E_{t1}^2) + E_{t2}^2 + I_{n1}^2 R_2^2$$

Yellow:
Equation

In the first parenthesis with noise, we have the noise source from the positive input of the amplifier. In this parenthesis, we have also noise voltage at the amplifier's negative input. Noise in the R_1 is reflected to the output amplified by the square of the ratio between R_2/R_1 . Noise I_{n1} goes directly through R_2 to the end. Noise voltage in the feedback resistance R_2 will be directly on the output.

The expression we have calculated is the noise at the output. As previously mentioned, it is beneficial to find the equivalent noise level at the input. The method we described earlier did this by dividing the noise level at the output with the system gain. Now we have a little choice since we have two inputs with two different system gains. (I.e. unless the amplifier is connected as an ideal differential amplifier: $R_2/R_1 = R_4/R_3$. In this case the gain is, respectively, plus and minus R_2/R_1 .)

Equivalent input noise for negative input

First, we find the equivalent noise for the negative (inverting) input. We find it by dividing E_{no}^2 with $(R_2/R_1)^2$. We get:

$$E_{ni1}^2 = \left(1 + \frac{R_1}{R_2}\right)^2 \left(\underbrace{E_{n2}^2 + E_{ip}^2 + E_{n1}^2}_{\text{green}} + \underbrace{R_1^2 I_{i2}^2}_{\text{pink}} + \underbrace{E_{i1}^2}_{\text{yellow}} + \underbrace{I_{n1}^2 R_1^2}_{\text{pink}} + \underbrace{I_{n2}^2 R_p^2}_{\text{green}} \right) \left(1 + \frac{R_1}{R_2}\right)^2$$

In the first noise-parenthesis, we have the input noise voltages of the amplifier and the noise of the parallel resistance at the positive input. Since R_2 is often much greater than R_1 the parenthesis will go towards 1 and the noise voltages will contribute with a weight of one. The amplifier noise current on the positive side will give a voltage over the parallel resistance and have the same weight as the previous. The noise in the feedback resistance (R_2) and the negative input (I_{n1}) will go through R_1 and result in a noise voltage that is at product of these currents and the resistance. The noise in R_1 is independent of all other resistances.

Equivalent input noise for positive input

To find the equivalent input noise to the positive input we divide E_{no}^2 by $(1+R_1/R_2)^2$. We will then have:

$$E_{ni2}^2 = \underbrace{(E_{n2}^2 + E_{ip}^2 + E_{n1}^2)}_{\text{green}} + \left(\frac{R_1}{R_1 + R_2}\right)^2 \underbrace{(E_{i2}^2)}_{\text{pink}} + \left(\frac{R_2}{R_1 + R_2}\right)^2 \left(\underbrace{E_{i1}^2}_{\text{yellow}} + \underbrace{I_{n1}^2 (R_1 \parallel R_2)^2}_{\text{pink}} + \underbrace{I_{n2}^2 R_p^2}_{\text{green}} \right)$$

The amplifier input noise voltages and the noise from the parallel resistance are reflected directly to the input. Noise voltage from the feedback resistance is reduced significantly if R_2 is much larger than R_1 . The noise voltage from R_1 will also be reduced but most when R_2 is small compared with R_1 . The noise current from the inverting input goes through the parallel coupling of R_1 and R_2 while the noise current from the non-inverting input goes through the parallel resistance on a positive side: R_p .

Ideal differential amplifier network

Now we will discuss the case when the gain is equal (but opposite) for both inputs. This is the case when: $R_2/R_1 = R_4/R_3$.

The gain factor for negative input will be $-R_2/R_1$ while for the positive input it will be R_2/R_1 . The square of the gain for both is equal and we name this as K_t . We have then:

$$E_{ni1}^2 = E_{ni2}^2 = E_{ni}^2 = E_{no}^2 / K_t^2$$

The equivalent input noise is for both inputs:

$$E_{ni}^2 = \left(1 + \frac{R_1}{R_2}\right)^2 (E_{n1}^2 + E_{ip}^2 + E_{n2}^2) + \left(\frac{R_1}{R_2}\right)^2 (E_{i2}^2) + E_{i1}^2 + I_{n1}^2 R_1^2 + I_{n2}^2 R_p^2 \left(1 + \frac{R_1}{R_2}\right)^2$$

Yellow:
Equation

This is the same expression that we found a little earlier for the negative input.

Example: 741 Op-Amp

- Goals:
- 1) Find the total output noise
 - 2) Find the total equivalent input noise at the negative input.
 - 3) Signal when the S/N=1.

Values: $E_n = 20nV/\sqrt{Hz}$

$I_n = 0.5pA/\sqrt{Hz}$

$R_1=R_3=1k\Omega$

$R_2=R_4=50k$

Assume a 1MHz gain-bandwidth product.

Ignore other types of noise than those mentioned.

Solution:

We use the expressions for the E_{no} and E_{ni1} and puts up the table with the following solutions for task 1) and 2)

Noise Source	Noise Value	Gain Multiplier	Output Noise Contribution	Input Noise Contribution
R ₁	4nV/√Hz	50	200nV/√Hz	4nV/√Hz
R ₂	28.3nV/√Hz	1	28.3nV/√Hz	0.556nV/√Hz
R _p	3.96nV/√Hz	51	202nV/√Hz	4.04nV/√Hz
E _{n1}	14.14nV/√Hz	51	721nV/√Hz	14.4nV/√Hz
E _{n2}	14.14nV/√Hz	51	721nV/√Hz	14.4nV/√Hz
I _{n1}	0.5pA/√Hz	50k	25nV/√Hz	0.5nV/√Hz
I _{n2}	0.5pA/√Hz	49.98k	25nV/√Hz	0.5nV/√Hz
Total Noise Contributions			1059.5nV/√Hz	21.16nV/√Hz

We see that E_{n1} and E_{n2} are dominating at both output and input.

IN5230

Noise in amplifiers with feedback

19

Solution for task 3):

With a gain of approx. 50 and a gain-bandwidth of 1MHz the -3dB bandwidth is 1MHz/50 = 20kHz.

However the noise bandwidth is not equal to the -3dB bandwidth.

During our earlier discussions of the signal bandwidth and noise bandwidth, we found that the noise bandwidth is $(\pi/2)$ times the signal bandwidth. We will then end up with a noise bandwidth equal to $(\pi/2)*20kHz=31.42kHz$. We calculate for E_{no} and E_{ni} and get:

$$E_{no} = 1059.5nV / \sqrt{Hz} \cdot \sqrt{31.42kHz} = 188\mu V$$

and

$$E_{ni} = 21.16nV / \sqrt{Hz} \cdot \sqrt{31.42kHz} = 3.75\mu V$$

In other words: When the signal is 3.75μV it is equal to the noise (S/N=1).

Some general comments about differential amplifiers

Typically operational amplifiers contains a balanced differential input stage. Then the inputs will be symmetrical and $E_{n1} = E_{n2}$. If the data sheet for the amplifier contains only one E_n value, you can divide this by $\sqrt{2}$ and use the new value at both inputs.

Alternatively, in an inverting configuration, it is often easier to use the standard E_n and I_n , as shown in the figure.

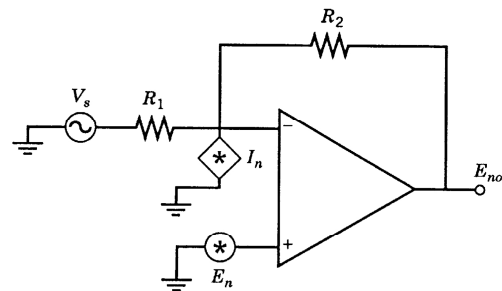

Figure 3-7 Simplified inverting amplifier with noise sources in place.

An expression for the noise on the output is:

$$E_{no}^2 = (1 + R_2/R_1)^2 E_n^2 + R_2^2 I_n^2$$

In this expression we neglect the noise in the resistors.

The noise matched source resistance, R_0 , is as previously discussed: E_n/I_n . From the equation above we have that R_0 can be expressed as:

$$R_0 = E_n/I_n = R_1 R_2 / (R_1 + R_2) = R_1 \parallel R_2$$

When the source resistance R_1 is less than R_0 , E_n is dominant whereas when R_1 is greater than R_0 , I_n is in dominant.

In schematics with high gain is R_2 much larger than R_1 . When this is the case is R_0 equal to R_1 .

NB! By setting R_1 equal to R_0 we get the minimum noise factor but not the smallest noise. (Neglecting the signal level and only focusing on noise, we achieve the smallest noise when R_1 goes to towards 0.)

Method for measurement of I_n

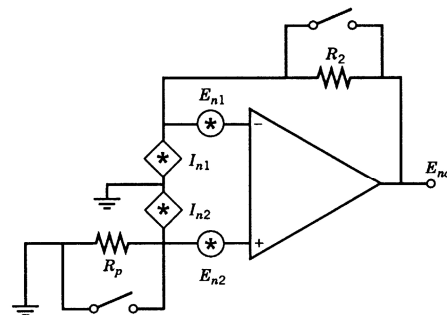

Figure 3-8 Circuit for measuring current noise sources.

The figure shows a method for measuring I_n . It is not suited for the most noise-sensitive amplifiers.
Method:

1. Both switches are closed (conducting) and E_{no} is measured. The noise measured is E_n . NB! Since the gain is only 1 contribution from the following stages will also contribute.
2. When the switch over R_2 is open the noise at the output will have contributions from E_n , $I_{n1}R_2$ and E_{n2} . Thermal noise through R_2 can be calculated. Now it is only I_{n1} that remains and it can be calculated from the measurement of output noise and the equations we have found previously.

- Then we open the switch over R_p and the noise is measured again at the output. The new contributions to the output noise are now R_p (which can be calculated) and $I_{n2}R_p$. Thus, we can find I_{n2} .

When $R_p = 0$ we have that I_{n2} is effectively short circuited and only I_{n1} contributes with noise to E_{ni1} .

When to measure I_n "the source resistance" R_1 should be made so large that $I_{n1}^2 R_1^2$ becomes dominant.

Inverted negative feedback

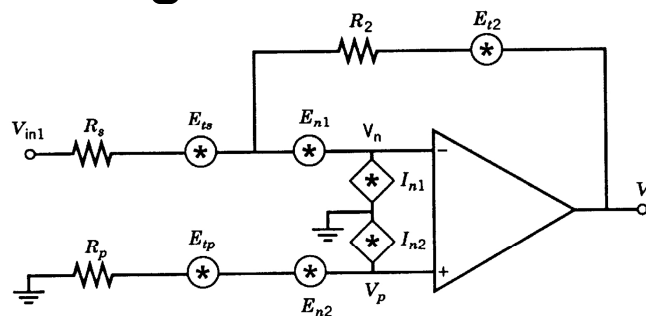

Figure 3.9 Simplified closed-loop inverting amplifier.

The inverted amplifier configuration that we have discussed earlier is often used. It is used by grounding V'_{in2} , replace R_1 by R_s and by selecting R_p so that it is equal to the parallel value of R_s and R_2 . (R_p is necessary if there are a significant current in the positive terminal. If the input is high impedance, like in CMOS, R_p can be ignored.)

When we shall find the equivalent noise at the input, it will be at the V_{in1} input.

We use the term we found earlier, and insert the new indexes:

$$E_{ni1}^2 = \left(1 + \frac{R_s}{R_2}\right)^2 (E_{n1}^2 + E_{n2}^2 + E_{tp}^2 + I_{n2}^2 R_p^2) \\ + \left(\frac{R_s}{R_2}\right)^2 (E_{t2}^2) + E_{ts}^2 + I_{n1}^2 R_s^2$$

We just regroup and get:

$$E_{ni1}^2 = E_{ts}^2 + R_s^2 (I_{n1}^2 + I_{t2}^2) \\ + \left(1 + \frac{R_s}{R_2}\right)^2 (E_{n1}^2 + E_{n2}^2 + E_{tp}^2 + I_{n2}^2 R_p^2)$$

Here is $I_{t2} = E_{t2}/R_2$.

In the specifications for an amplifier, E_n and I_n is often given according to:

$$E_n = \sqrt{E_{n1}^2 + E_{n2}^2}$$

**Red:
Equations**

and

$$I_n = I_{n1} = I_{n2}$$

By using these relations the expression above is simplified to:

$$E_{ni}^2 = E_{ni1}^2 = E_{ts}^2 + I_n^2 R_s^2 + \left(1 + \frac{R_s}{R_2}\right)^2 (E_n^2 + E_{tp}^2 + I_{n2}^2 R_p^2) + I_{t2}^2 R_s^2$$

We now define a new equivalent noise voltage E_{na}^2 expressed as:

$$E_{na}^2 = \left(1 + \frac{R_s}{R_2}\right)^2 (E_n^2 + E_{tp}^2 + I_{n2}^2 R_p^2) + I_{t2}^2 R_s^2$$

The position of E_{na}^2 is given in the following figure:

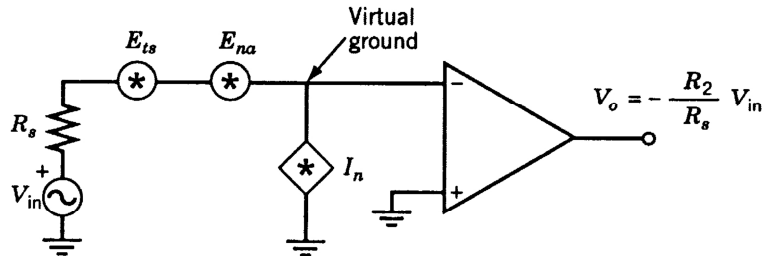

Figure 3-10 Simplified open-loop inverting amplifier with noise sources in place.

The equivalent input noise is now simplified to:

$$E_{ni}^2 = E_{ts}^2 + E_{na}^2 + I_n^2 R_s^2$$

Yellow:
Equation

The inverting feedback amplifier can be represented by the equivalent form above. Here E_{na}^2 represents the noise in R_2 , R_p and the amplifier noise s .

IN5230

Noise in amplifiers with feedback

29

In amplifiers with MOSFET input, R_p can often be ignored since the amplifier noise current is very small. Moreover, low noise amplifiers often require feedbacks giving a gain of 30 or more. When this is the case R_2 is much larger than R_s which is larger than R_p . Then the expression for the equivalent input noise is simplified to:

$$E_{ni}^2 = E_{ts}^2 + E_n^2 + (I_n^2 + I_{t2}^2) R_s^2$$

Non-inverted negative feedback

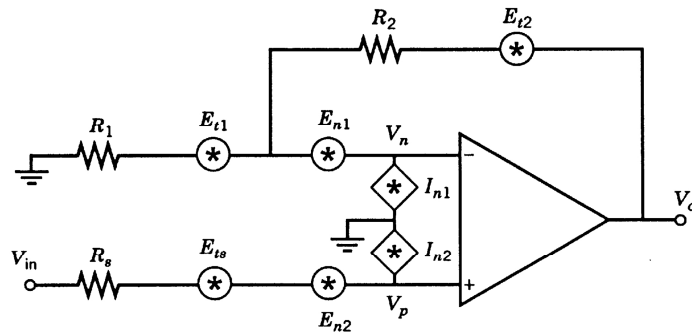

Figure 3-11 Simplified closed-loop noninverting amplifier.

In the non-inverted connection the resistance R_p represent the source resistance. Hence we instead will name it R_s . We also name the input V_{in2} as V_{in} .

We shall now show how this noise schematic based on a noise assessment may be reduced to a simpler form without feedback.

First, we start with the expression we found earlier and put in the new indexes.

IN5230

Noise in amplifiers with feedback

31

$$E_{no}^2 = \left(1 + \frac{R_2}{R_1}\right)^2 (E_{n1}^2 + E_{n2}^2 + E_{ts}^2 + I_{n2}^2 R_s^2) + \left(\frac{R_2}{R_1}\right)^2 (E_{t1}^2) + E_{t2}^2 + I_{n1}^2 R_2^2$$

We use the term $E_n = \sqrt{E_{n1}^2 + E_{n2}^2}$

and get:
$$E_{no}^2 = \left(1 + \frac{R_2}{R_1}\right)^2 (E_n^2 + E_{ts}^2 + I_{n2}^2 R_s^2) + \left(\frac{R_2}{R_1}\right)^2 (E_{t1}^2) + E_{t2}^2 + I_{n1}^2 R_2^2$$

To find the equivalent input noise we divide the noise by the gain. The gain is equal to: $(1+R_2/R_1)^2$.

We will then have:

$$E_{ni}^2 = E_{ts}^2 + E_n^2 + \left(\frac{R_1}{R_1 + R_2}\right)^2 E_{t2}^2 + \left(\frac{R_2}{R_1 + R_2}\right)^2 E_{t1}^2 + I_{n1}^2 (R_1 \parallel R_2)^2 + I_{n2}^2 R_s^2$$

If we assume:

$$I_n = I_{n1} = I_{n2}$$

we can define a new noise voltage E_{nb}^2 :

$$E_{nb}^2 = E_n^2 + \left(\frac{R_1}{R_1 + R_2}\right)^2 (E_{t2}^2) + \left(\frac{R_2}{R_1 + R_2}\right)^2 (E_{t1}^2) + I_n^2 (R_1 \parallel R_2)^2$$

IN5230

Noise in amplifiers with feedback

32

$$E_{nb}^2 = E_n^2 + \left(\frac{R_1}{R_1 + R_2}\right)^2 (E_{t2}^2) + \left(\frac{R_2}{R_1 + R_2}\right)^2 (E_{t1}^2) + I_n^2 (R_1 \parallel R_2)^2$$

We create a new form with the new noise voltage as follows:

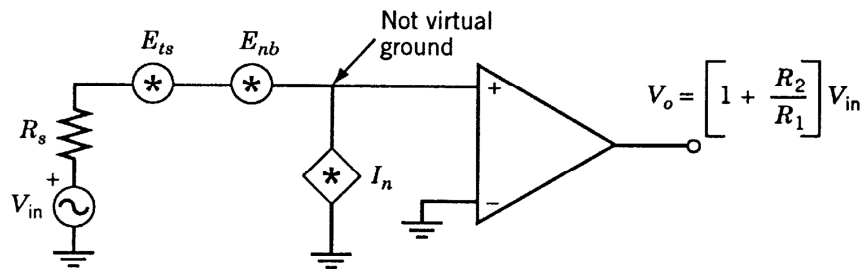

Figure 3-12 Simplified open-loop noninverting amplifier with noise sources in place.

The new equivalent input noise can be expressed as:

$$E_{ni}^2 = E_{ts}^2 + E_{nb}^2 + I_n^2 R_s^2$$

Yellow:
Equation

Here, E_{nb}^2 contains noise from the feedback and the voltage noise of the amplifier.

Positive feedback

Positive feedback is intentionally utilised in oscillators. In other cases unwanted feedbacks often occurs that create undesirable results.

In principle the noise considerations for positive feedbacks are similar with the considerations for negative feedbacks.

Often it will be desirable to create a low noise oscillator. Noise in oscillators results in variations of frequency. This can be seen as a "skirt" around the signal when inspected on a spectrum analyzer. To reduce this, first you have to create a low-noise amplifier and then use a low-noise feedback network around the amplifier.

Frequency jitter is least in x-tal oscillators due to the sharp filter characteristics of the crystal. In RLC-oscillators high Q-factors of the filter components will contribute to less jitter.

Example: How can one tell if an amplifier network is stable?

Assume an amplifier that has a open loop gain of 80dB and poles at 1, 6 and 22MHz. We will check whether this is stable when it have a negative closed loop feedback that provides a gain of 40dB.

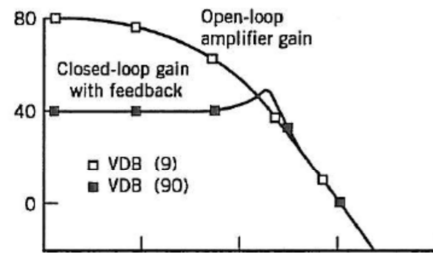

We get simulation results as given above. We find that at 12MHz is the gain larger than what we got with a open-loop! It means that we have positive feedback. The simulation shows that at 12MHz is the phase shift positive. It means that the amplifier is unstable. This is something that the noise analysis will not show.

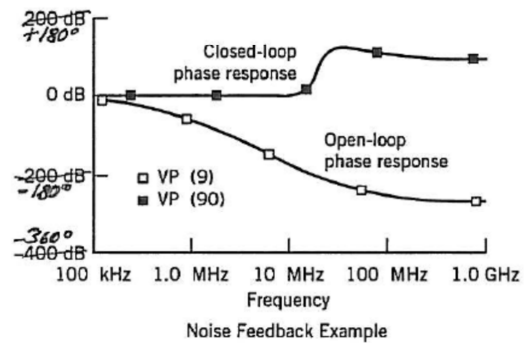

Figure 3-13 Effect of positive feedback as shown by PSpice.