

Subject matter areas of IT user competence

- Aim
 - Identify the three **subject matter areas** of competence for IT users for your Assignments
- Literature
 - Textbook chapter 3

Fagområde
Field
Sujet
tema
Sujeto

1

Competence

- Knowledge
 - The ranges of one's understanding, or information
 - The sum of what has been established by science
 - The data in a Knowledge Management Database
 - ...
- Competence
 - Abilities related to work
 - and also to other activities
 - Also called capacity
 - Includes
 - Skill
 - Understanding

2



Three traditions of user competence

Information systems: User capability

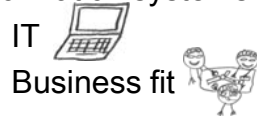

Library science: Information literacy

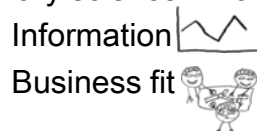

Schools

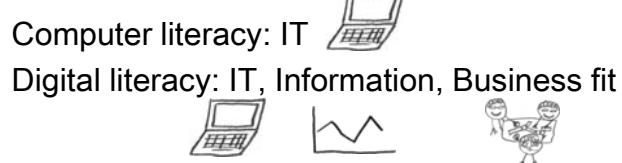

3

IT related problems



When people ask you for help concerning IT, or when you observe their mistakes, which issues do they struggle with? Write down 1-3 issues.

4

Subject matter areas of competence

- **Information (data)**
 - which represents the domain
- **Information Technology**
 - Functionality, user interface
- **Business fit**
 - Activities where the IT is going to be used

5

Information

KARLSTAD KARLSTAD
Armchair Three-seat sofa with long cover
£239 £339

Domain



Information technology



jellyflux.wordpress.com

Business fit

6



Information

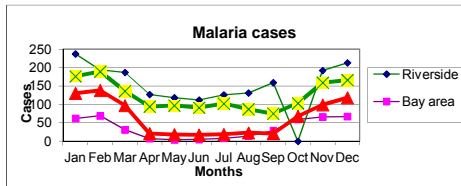

Domain



IT

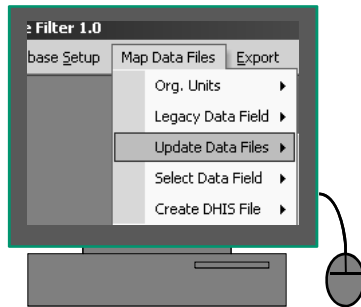

Business fit



Information – Object diagram

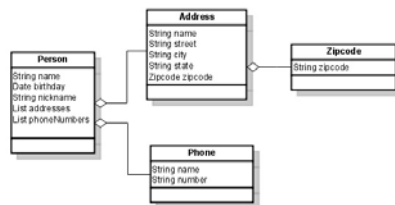

Domain



IT – Deployment diagram

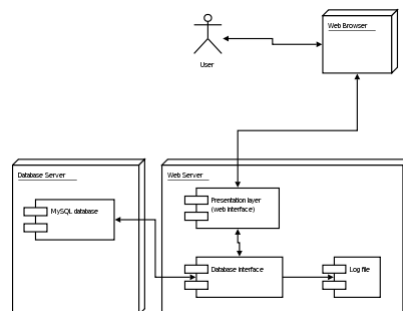

Business fit – Use case

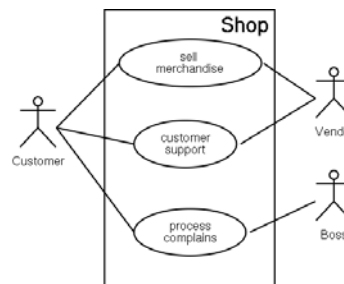

8

Contents

Information

It is raining cats and dogs these days. We hardly go out of the house.

Domain



IT



Business fit

Writing and editing

Format

Information

Top margin: 2.5cm
Left margin: 2.5cm

Font: Times Roman

Domain

It is raining cats and dogs these days. We hardly go out of the house.

IT

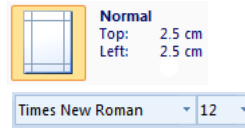

Business fit

Formatting

9

Learning the skills of IT user competence

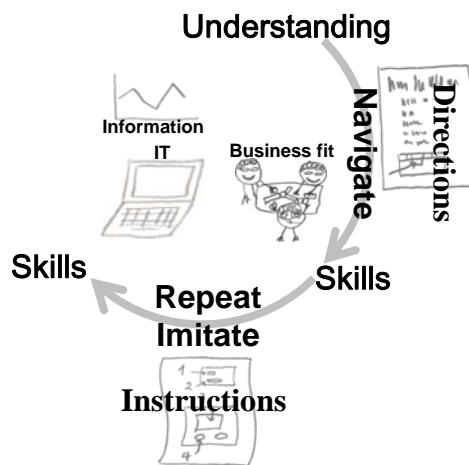

10