

INF3480/INF4380 - Assignment 1

Eirik Kvalheim and Jørgen Nordmoen

Due: Thursday, February 22nd 2018

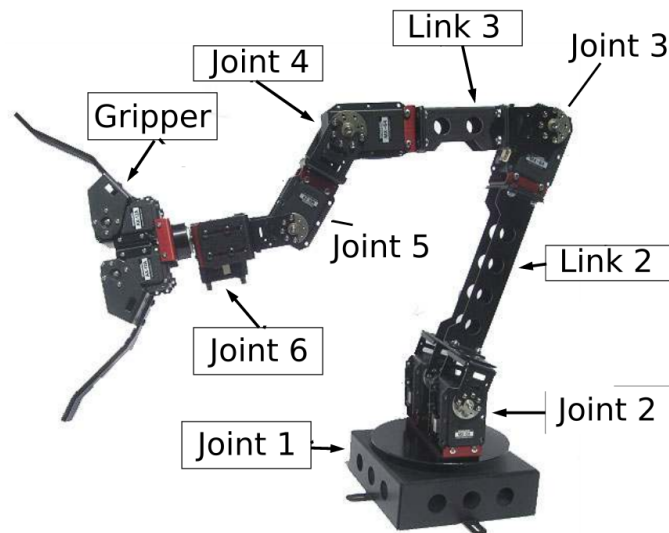

Figure 1: The CrustCrawler robot

Introduction

Figure 1 displays the CrustCrawler robot which we will work with in the compulsory assignments in INF3480/INF4380. The CrustCrawler is a six-axis robotic arm with an optional gripper attachment. The base of the arm is a turntable (*Joint 1*) which allows the arm to turn around its own axis. The arm itself is composed of 6 servo motors to allow for multiple degrees of freedom. Attached to the turntable is a double actuator joint (*Joint 2*), composed of two servos. *Link 2* connects *Joint 2* and *Joint 3*. We then have *Link 3*, connected to *Joint 4*. Connected directly to *Joint 4* is another servo, *Joint 5* which is parallel to *Joint 4*, *Joint 3* and *Joint 2*. Lastly the axis of rotation for *Joint 6* is perpendicular to the axis of rotation of *Joint 5*. The optional gripper is attached to *Joint 6*.

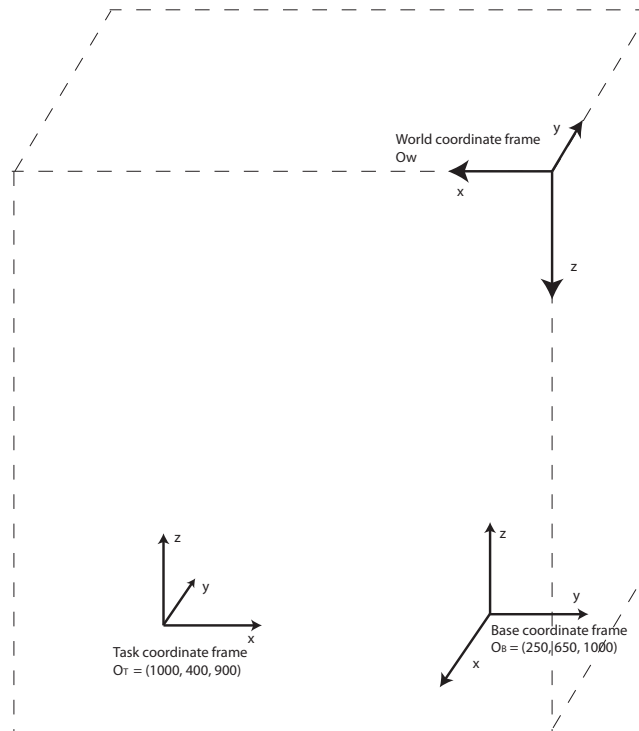

Figure 2: Coordinate frames (see also figure 4)

Task 1 - Transformations

Figure 2 shows three coordinate frames and the direction of the axes. We name the coordinate frames *World coordinate frame* $\{W\}$, *Base coordinate frame* $\{B\}$ and *Task coordinate frame* $\{T\}$.

Origin of coordinate frame $\{B\}$, relative to $\{W\}$, is located at position

$$O_B = (250, 650, 1000) \quad (1)$$

Origin of coordinate frame $\{T\}$, again relative to $\{W\}$, is located at position

$$O_T = (1000, 400, 900) \quad (2)$$

- The axes Z_W , Z_B and Z_T are parallel to each other
- The axes X_W , Y_B and X_T are parallel to each other
- The axes Y_W , X_B and Y_T are parallel to each other

Task Find T_T^B (the transformation matrix expressing the position and orientation of $\{T\}$ with respect to $\{B\}$, said in other words; a vector that goes from $\{B\}$ and ends up in $\{T\}$).

NOTE Show your solution by setting up the necessary expressions, formulas and calculations clearly.

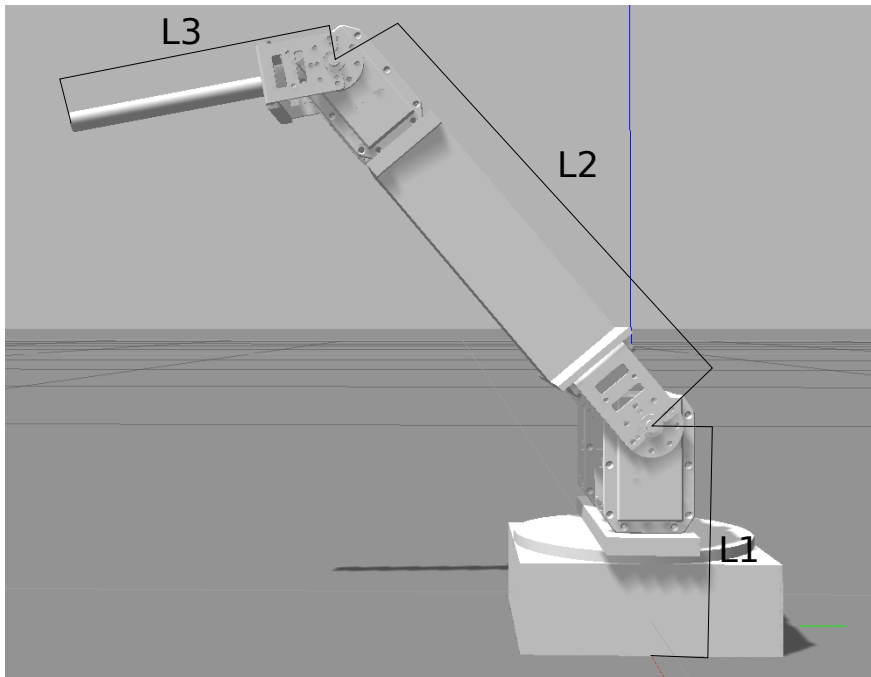

Figure 3: Simplified robot model in Gazebo

Task 2 - Forward Kinematics I

To simplify the exercise we will now look at a restricted model of the CrustCrawler robot. We remove joints [4, 5, 6] so that the CrustCrawler resembles the arm shown in figure 3. This simplified version only has three joints and three links.

- a) Sketch the workspace of the robot (a quick 3D drawing from top and side view is sufficient).
- b)
 1. Draw a simple 3D illustration of the robot, showing the coordinate frames and the Denavit-Hartenberg parameters.
Use the standard for symbolic representation of 3D robot joints, found in Chapter 1.1.1 in the course book. You can see an example of a correct 3D representation of a robot on page 85 in the course book, figure 3.7.
 2. Explain (briefly) your choice of origin and rotation axis.
 3. Show the DH-parameters in a table
- c) Calculate the forward kinematics for this robot. Your answer should be a transformation matrix T_t^B denoting the transformation of the tool coordinate frame $\{t\}$ located at the tip of the arm, with respect to the base coordinate frame $\{B\}$. This transformation matrix is a function of the three joints.

NOTE *The functions `simplify()` and `subs()` can be useful MATLAB tools for task 2c. However, forward kinematics must be calculated by hand on the exam, so we strongly advise you to familiarize yourself with this process.*

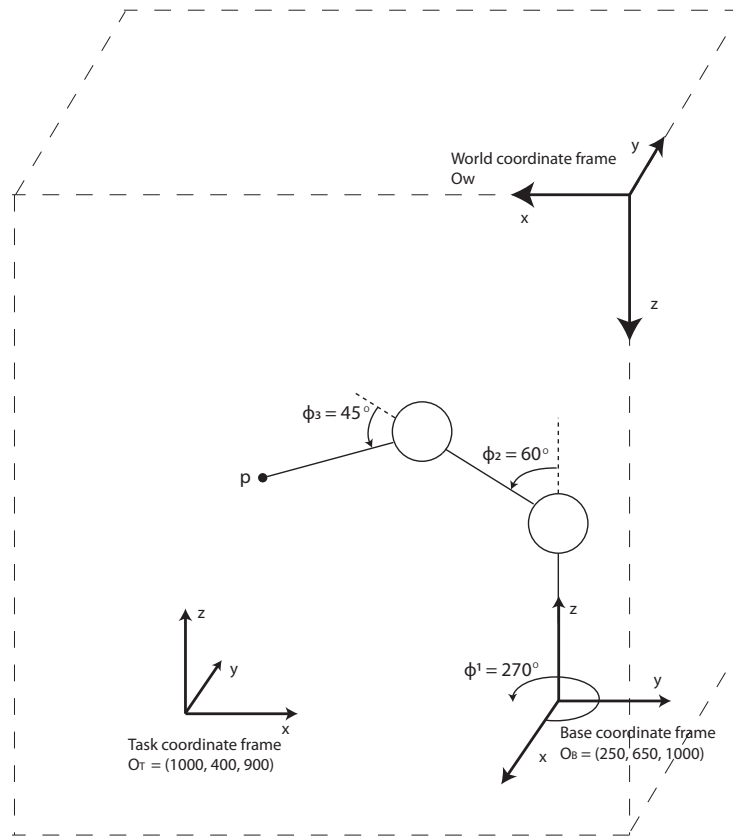

Figure 4: Robot with respect to World and Task frame

Task 3 - Forward Kinematics II

Point p is located at the tip of the robot (the last link). Adjust the robot as displayed in Figure 4, where $\phi_1 = 270^\circ$, $\phi_2 = 60^\circ$, $\phi_3 = 45^\circ$.

These (ϕ) angles are of course not to be used directly, **you have to figure out the correct θ -angles for your robot configuration**, with respect to how you have used the DH-convention to describe the robot. Link lengths in the figure are not proportional to the real robot.

Use the following dimensions in your calculation:

- $L1 = 100.9mm$
- $L2 = 222.1mm$
- $L3 = 136.2mm$

Task Find p^T , the coordinates of point p given in task coordinate frame $\{T\}$.

HINT Use your calculations from task 1 and 2c to find the answer.

Task 4 - Inverse Kinematics

- a) What are the two most common ways of deriving inverse kinematics? Describe shortly how you do them, and which one you will be using in b).
- b) Derive the inverse kinematic equations for the simplified robot, and show the different steps.
- c) How many solutions exist for the joint angles given an arbitrary position of the tip of link 3? We do not have any physical restriction on θ_1 , and you can also assume that there is no physical restriction on θ_2 other than the angles that would place L2 right on top of L1.

NOTE We advise students to do 4b) by hand. Similar tasks will be given on the exam, and an understanding of how to calculate the inverse kinematic by hand is very valuable!

Requirements:

Each student must hand in their own assignment, and you are required to have read the following declaration to student submissions at the department of informatics: <http://www.if.uio.no/studinf/skjemaer/declaration.pdf>

IMPORTANT: Name the pdf file: “*inf3480-oblig1-your_username.pdf*”.

Submit your assignment at <https://devilry.if.uio.no>.

Your submission must include:

- A pdf-document with answers to the questions.
- The two illustrations asked for in question 2a and 2b
- **A README.txt containing a short reflection on the assignment;** what was difficult, what was easy, was there anything you could have done better?

If you have used MATLAB or other tools for computing an answer, your solution and approach must be illustrated and explained thoroughly in the pdf file.

The files containing the code must also be named and delivered.

Deadline: Thursday, February 22nd 2018

You can use the slack channel *assignment 1* for general questions about the assignment, and the channels *forward kinematics* and *inverse kinematics* for discussion. Do not hesitate to contact us if you have any further questions.

Eirik Kvalheim - eirikval@mail.uio.no
Daniel Sander Isaksen - daniesis@mail.uio.no
Sadegh Hosseinpoor - sadeghh@mail.uio.no
Fredrik Ebbesen - fredreb@mail.uio.no
Nikolai René Berg nikolber@mail.uio.no